

HDAVS Camera User's Manual

Version 1.0.0

Table of Contents

1	General Introduction	1
1.1	Overview	1
1.2	Features	1
2	Device Framework	2
3	Installation.....	7
4	Menu.....	12
4.1	HAVR Settings	12
4.2	Menu Operation	12
	Appendix I Maintenance.....	14

Welcome

Thank you for purchasing our HDAVS camera!

This user's manual is designed to be a reference tool for your system.

Please read the following safeguard and warnings carefully before you use this series product!

Please keep this user's manual well for future reference!

Important Safeguards and Warnings

1 . Electrical safety

- All installation and operation here should conform to your local electrical safety codes.
- The power shall conform to the requirement in the SELV (Safety Extra Low Voltage) and the Limited power source is rated DC 12V or AC24V in the IEC60950-1. (Power supply requirement is subject to the device label).
- Please install easy-to-use device for power off before installing wiring, which is for emergent power off when necessary.
- Please check if the power supply meets the requirements of working voltage of the camera before operating the device (The material and length of the power supply cable will influence terminal voltage value).
- Please prevent the line cord from being trampled or pressed, especially the plug, power socket and the junction from the device.

2 . Environment

- Please don't aim the device at strong light (such as lighting, sunlight and so on) to focus.
- Please transport, use and store the device within the range of allowed humidity and temperature.
- Please do not allow water and other liquid falling into the camera in case that the internal components are damaged.
- Please keep the sound ventilation in case of heat accumulation.
- Heavy stress, violent vibration or water splash are not allowed during transportation, storage and installation.
- Please pack the device with standard factory packaging or material with same quality when transporting the device.
- It is recommended to use the device together with lightning protection device to enhance lightning protection effect.
- It is recommended to GND the device to enhance device reliability.
- It is advised to use qualified video transmission cable to improve video quality. It is recommended to use 75-3 coaxial cable or higher standard.

Warning

- Please use the standard accessories provided by manufacturer and make sure the device is installed and fixed by professional engineers.
- Please prevent the device surface from the radiation of laser beam when using laser beam device.

- Please do not provide two or more power supply modes for the device, otherwise it may cause damage to the device.

Statement

- Please refer to the actual product for more details; the manual is just for reference.
- The manual will be regularly upgraded according to the product update; the upgraded content will be added in the manual without prior announcement.
- Please contact the customer service for the latest procedure and supplementary documentation.
- The company is not liable for any loss caused by the operation which is not followed by the manual.
- Please refer to the company's final explanation if there is any doubt or dispute.

1 General Introduction

1.1 Overview

This series HDAVS camera conforms to the HDAVS standard. It supports video signal high-speed long distance transmission without any delay. It can be controlled by the HAVR conforming to the HDAVS.

1.2 Features

- Adopt high performance CMOS image sensor, megapixel definition.
- Support coaxial transmission of video, audio and control signal.
- For 720P series, support 75-3 coaxial cable transmission without any loss. The distance is over 800m. For 1080P series, support 75-3 coaxial cable transmission without any loss. The distance is over 500m.
- High speed, long distance real-time transmission.
- Support HDAVS HD video and analog video output.
- Support 3D noise reduction, excellent low illuminance performance.
- Support ICR switch to realize surveillance both in the daytime and at night.
- Support OSD menu adjustment parameters.
- Support smart IR function.
- Support WDR/DWDR function.
- Support DC 12V power supply. (Some models support DC 12V/AC 24V power supply).
- Support IP67 compliance.
- It can be applied to environments which requires high definition image, such as banking, supermarket, telecom, government, school, airport, factory, hotel, museum and etc.

2 Device Framework

See Figure 2-1 for the dimension of **model A**.

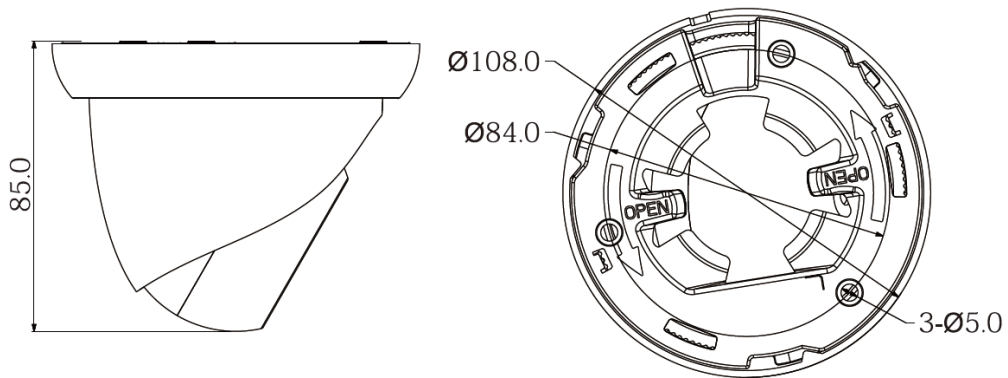

Figure 2-1

See Figure 2-2 for the structure components of **model A**.

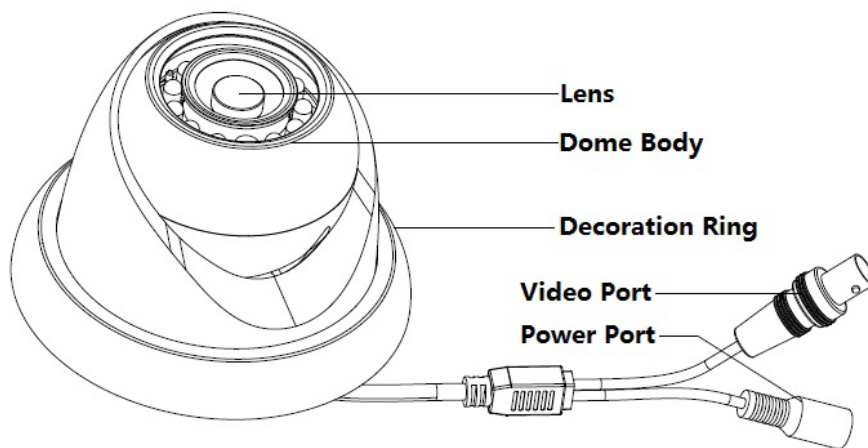

Figure 2-2

See Figure 2-3 for the dimension of **model B**.

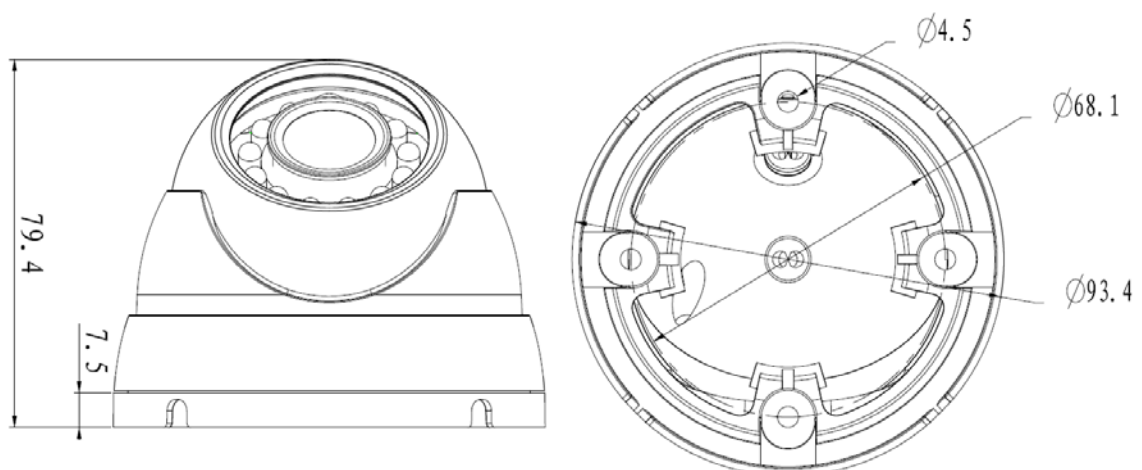

Figure 2-3

See Figure 2-4 for the structure components of **model B**.

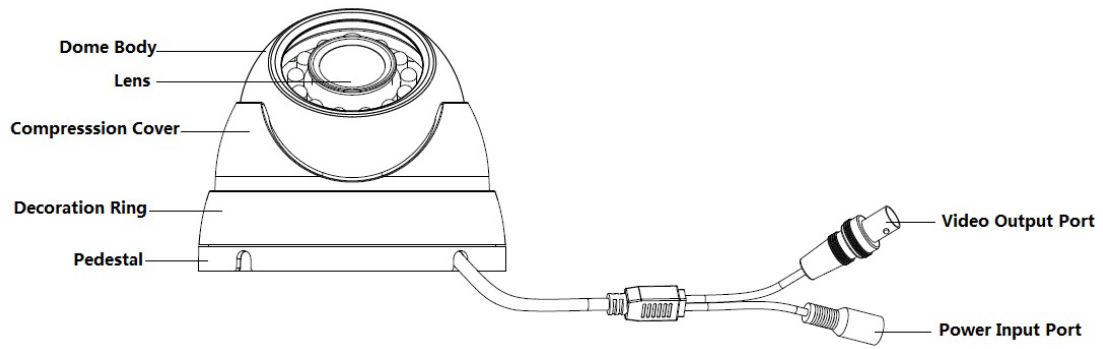

Figure 2-4

See Figure 2-5 for the dimension of **model C**.

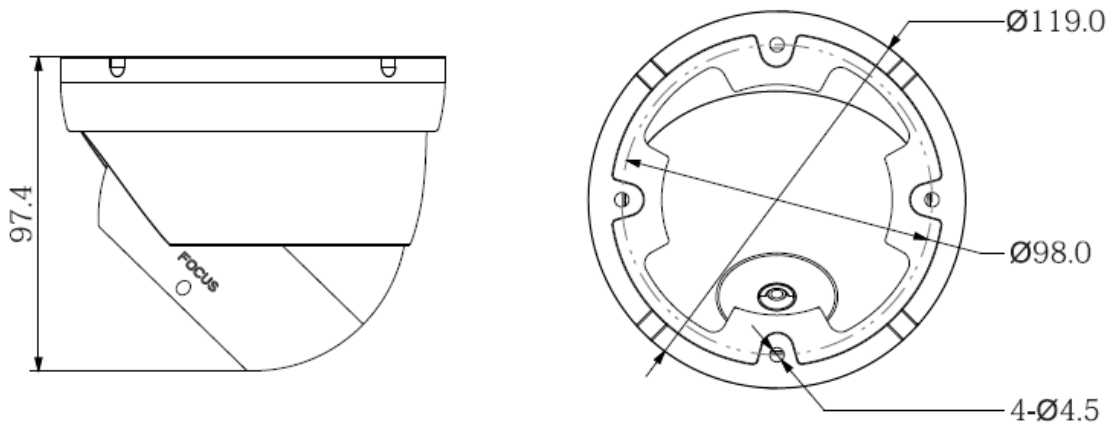

Figure 2-5

See Figure 2-6 for the structure components of **model C**.

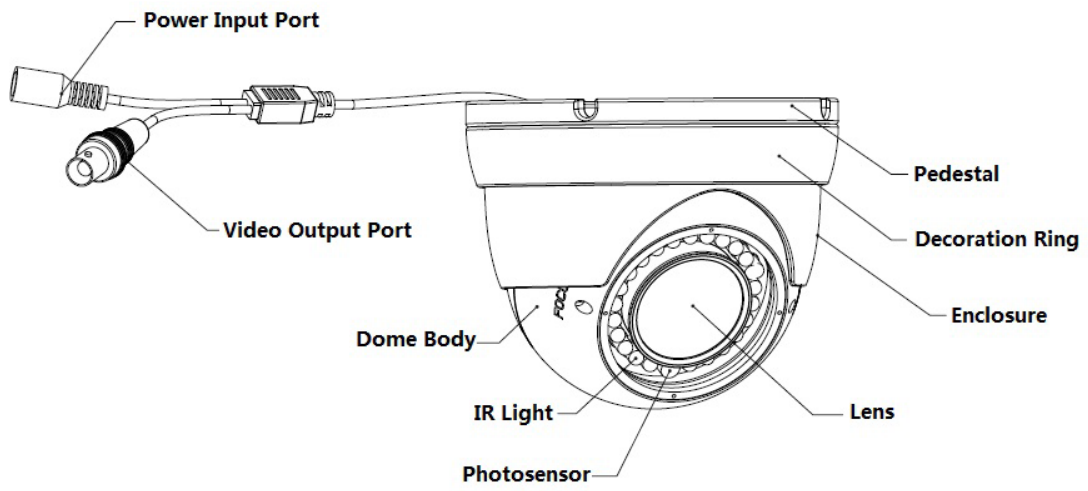

Figure 2-6

See Figure 2-7 for the dimension of **model D**.

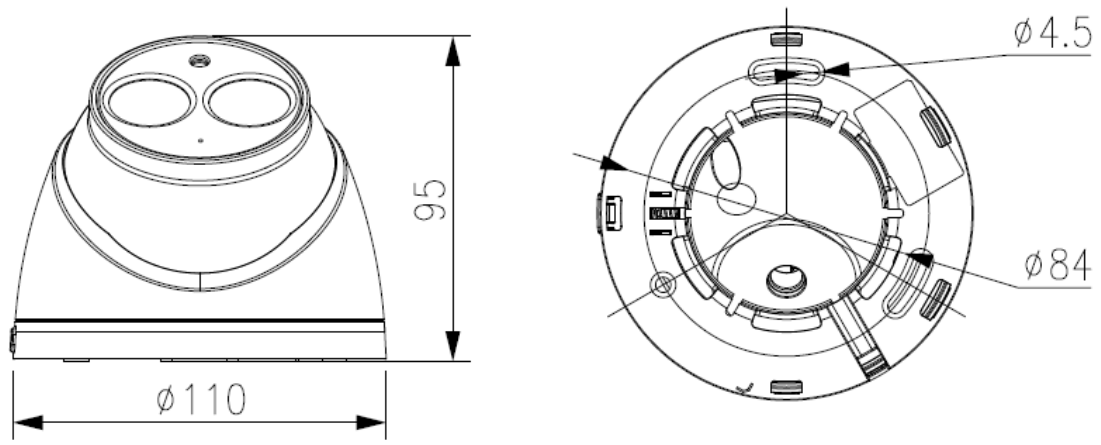

Figure 2-7

See Figure 2-8 for the structure components of **model D**.

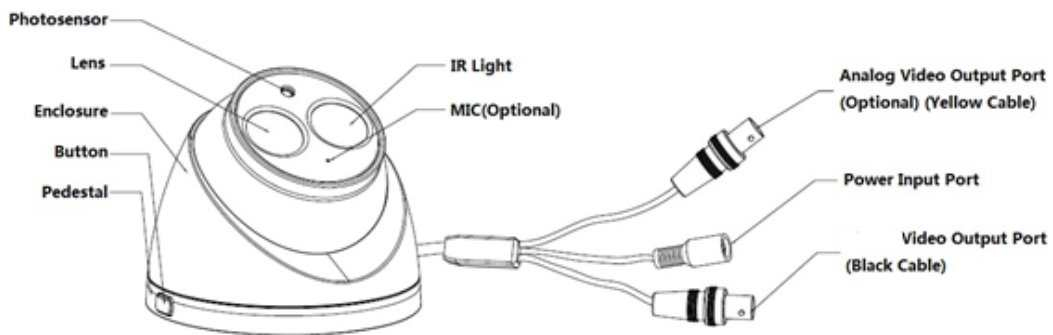

Figure 2-8

See Figure 2-9 for the dimension of **model E**.

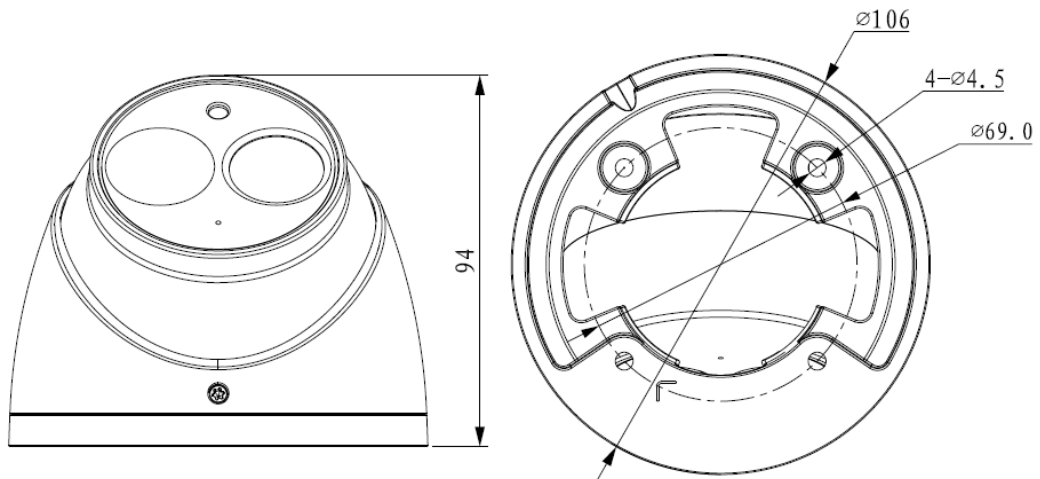

Figure 2-9

See Figure 2-10 for the structure components of **model E**.

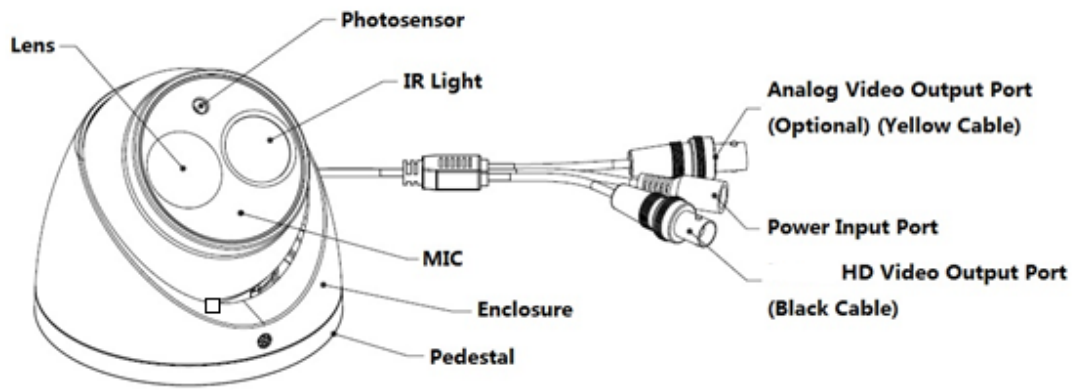

Figure 2-10

See Figure 2-11 for the dimension of **model F**.

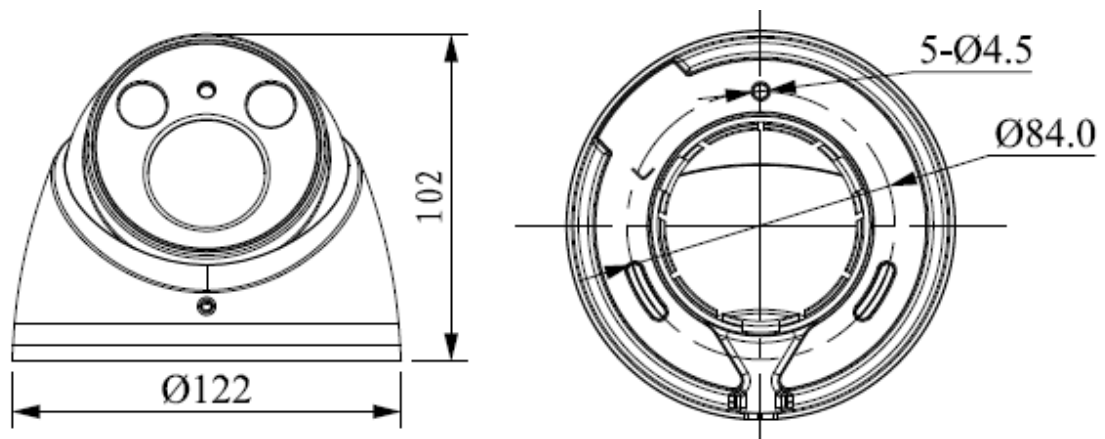

Figure 2-11

See Figure 2-12 for the structure components of **model F**.

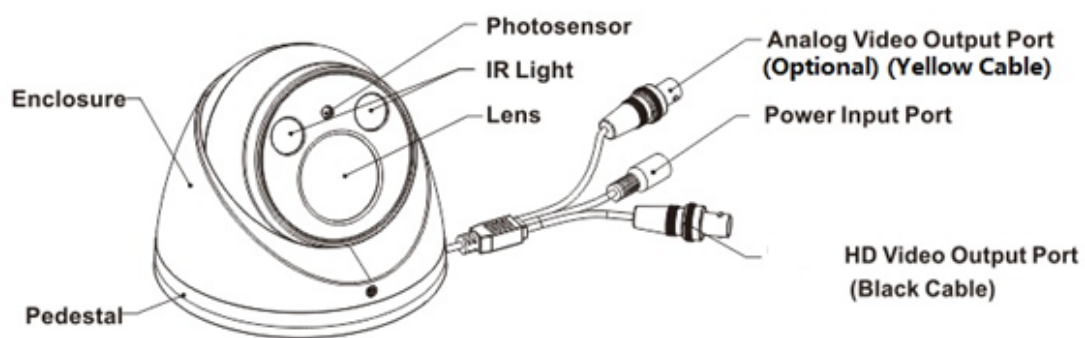

Figure 2-12

See Figure 2-13 for the cable of single channel video output.

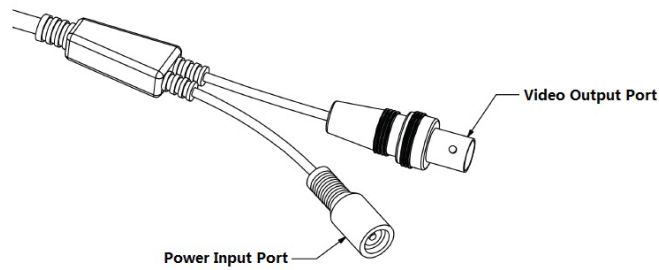

Figure 2-13

Note:

There is only one video port for some cameras, which is shown in Figure 2-12, it outputs HD video signal by default, it needs to enable self-adaptation function in the OSD menu to switch to standard definition video signal.

See Figure 2-14 for the dual power cable.

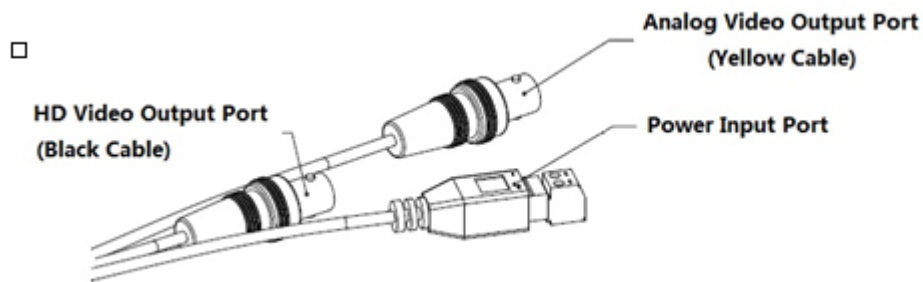

Figure 2-14

Note: Camera models with dual power use the cable structure shown in Figure 2-13; the power input port supports DC12V/AC24V power supply.

3 Installation

Dome camera mainly uses ceiling installation; installation surface includes ceiling and wall. Users can install the device with the installation position map and the screws in the accessories bag.

Attention:

- Please install the device in time after it is taken apart, which is to avoid the camera module being exposed to damp environment for too long.
- Before the installation, please make sure the installation surface is thick enough to sustain at least 3X weight of the camera.
- For the installation mode of side outlet, make sure the direction of side outlet is in accordance with that of the installation position map when sticking the installation position map. Besides, pull the cable through the pedestal cable slot before locking the screw.

Please refer to the following installation steps if it is model A, B or C.

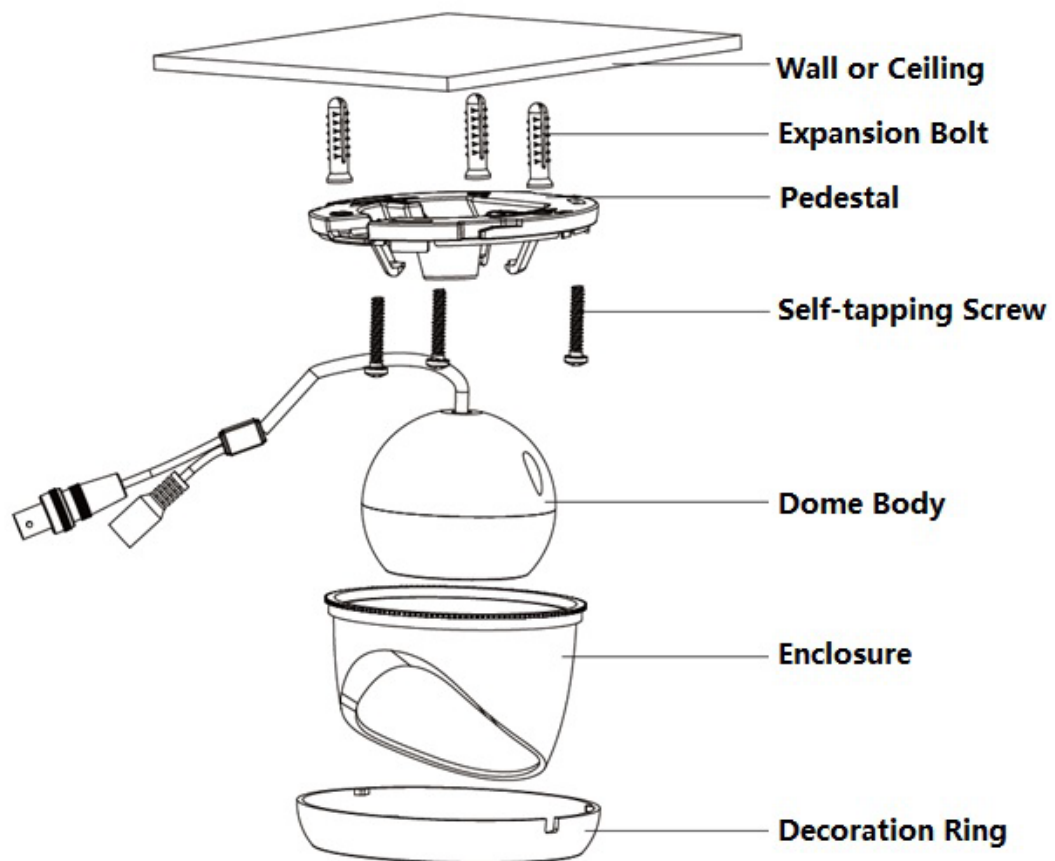

Figure 3-1

Step 1

Dismantle the pedestal. There are two ways to dismantle the pedestal according to different models.

- Model A: Hold the decoration ring tightly, rotate the pedestal counterclockwise, release the buckle and take off the pedestal.

- Model B or C: Hold decoration ring tightly and rotate away the pedestal counterclockwise.

Step 2

Take out the installation position map from the accessories bag, paste it on the ceiling or wall and dig holes on the installation surface according to the installation position map.

Step 3

Use tools to fix the expansion bolts into the installation holes.

Step 4

Adjust the pedestal location (pull the cable through side cable slot if it is side cable outlet). Align the bolt fixing hole of device pedestal with the expansion bolt fixing holes of the installation surface; insert the self-tapping screws into the expansion bolts and secure them firmly to fix the pedestal on the installation surface (if it is top outlet, pull the cable through the outlet hole on the installation surface after the pedestal is fixed firmly)

Step 5

Install dome body, enclosure (or compression cover) and the decoration ring according to different models:

- Model A: Close the buckle, rotate the enclosure and dome body to proper monitoring location, and finally rotate the decoration ring tightly.
- Model B: Rotate the decoration ring and fix it preliminarily, then rotate the compression cover and dome body to proper monitoring location, finally rotate the decoration ring tightly.
- Model C: Rotate the decoration ring and fix it preliminarily, then rotate the compression cover and dome body to proper monitoring location; connect the video output port of the device cable to the back-end coding device, and connect power port to the power; it is to adjust lens focal length to make image clear via focusing tool after image is displayed on the back-end coding device; finally rotate the decoration ring tightly.

So far, you have completed device installation and cable connection, you can check monitoring picture via back-end coding device.

Please refer to the following installation steps if it is model D or E.

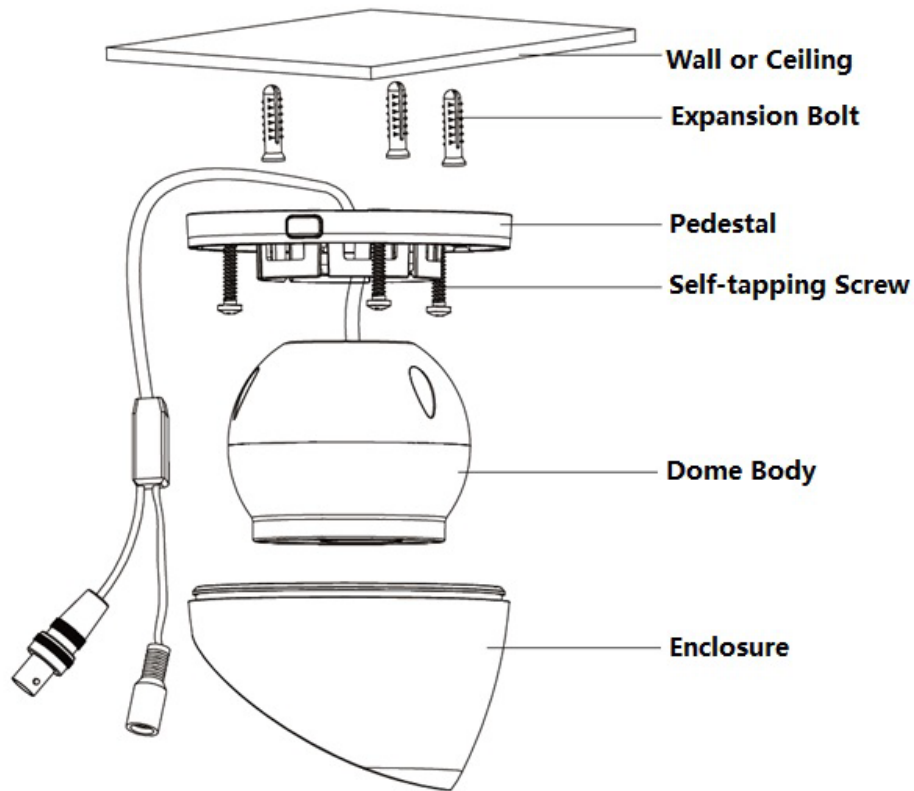

Figure 3-2

Step 1

Dismantle the pedestal according to different models:

- Model D: Press the button to release the pedestal. Press the lower dome enclosure of the cable outlet to separate pedestal from the enclosure.
- Model E: Unscrew the locking screw counterclockwise to release the pedestal.

Step 2

Take out the installation position map from the accessories bag, paste it on the ceiling or wall and dig holes on the installation surface according to the installation position map.

Step 3

Use tools to fix the expansion bolts into the installation holes.

Step 4

Adjust the pedestal location (pull the cable through side cable slot if it is side cable outlet). Align the bolt fixing hole of device pedestal with the expansion bolt fixing holes of the installation surface; insert the self-tapping screws into the expansion bolts and secure them firmly to fix the pedestal on the installation surface (if it is top outlet, pull the cable through the outlet hole on the installation surface after the pedestal is fixed firmly)

Step 5

Install the dome body and enclosure according to the different models:

- Model D: Insert the enclosure into the pedestal together with the dome body, rotate the enclosure and dome body to a proper monitoring location.

- Model E: Insert the enclosure into the pedestal together with the dome body, turn the locking screws clockwise and fix them preliminarily; rotate enclosure and dome body to a proper monitoring location; finally tighten the locking screws to fix it completely.

So far, you have completed device installation and cable connection, you can check monitoring picture via back-end coding device.

Please refer to the following installation steps if it is model F.

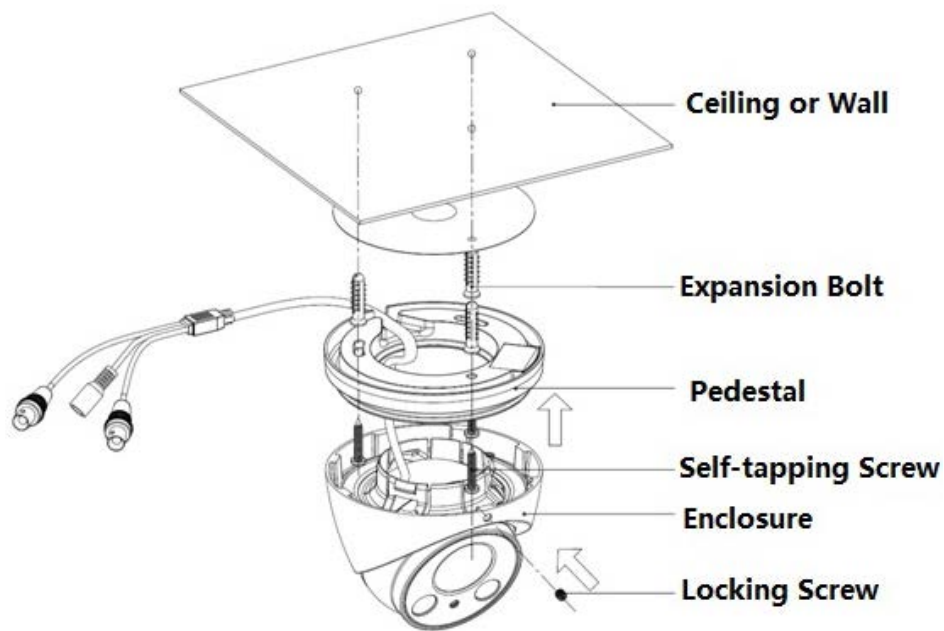

Step 1

Loosen the locking screw and take off the enclosure.

Step 2

Take out the installation position map from the accessories bag, paste it on the ceiling or wall and dig holes on the installation surface according to the installation position map.

Step 3

Use tools to fix the expansion bolts into the installation holes.

Step 4

Adjust the pedestal location (pull the cable through side cable slot if it is side cable outlet). Align the bolt fixing hole of device pedestal with the expansion bolt fixing holes of the installation surface; insert the self-tapping screws into the expansion bolts and secure them firmly to fix the pedestal on the installation surface (if it is top outlet, pull the cable through the outlet hole on the installation surface after the pedestal is fixed firmly)

Step 5

Rotate the enclosure and dome body to a proper monitoring location; insert it into the pedestal and tighten the locking screw.

Step 6

Connect the video output port of the device cable to the back-end coding device, and connect

power port to the power.

Step 7

Adjust the lens zoom and focus via back-end coding device to make image clear.

So far, you have completed the device installation and cable connection, you can check the monitoring image via back-end coding device.

4 Menu

4.1 HAVR Settings

This HDAVS camera series can adjust OSD menu via coaxial control. After connected the camera to the HDAVS series HAVR, from Main Menu->Setting->System->PTZ, you need to select the channel number for access and set control mode as HDAVS and the protocol as HD-AVS. Click "Save" button to save current setup. See Figure 4-1.



Figure 4-1

4.2 Menu Operation

Click the right mouse button and select "PTZ Control", then you will see the "PTZ Setup" menu, which is as shown in Figure 4-2 and Figure 4-3.



Figure 4-2



Figure 4-3

See Sheet 4-1 for the details of button functions.

Button	Function	
	Open menu	
	Select menu item	
	Select menu value	
	Adjust lens zoom and auto trigger focus	Note: Some of the buttons can only be applied for the motorized vari-focal camera.
	Adjust lens focus	
	Auto focus under current zoom rate	
	Lens reset	

Sheet 4-1

If there is “”, click the “Confirm” button in “Menu Operation” interface to go to the 2nd menu. Click “Return” button to go back to the previous menu interface.

Appendix I Maintenance

Attention:

Please maintain the device according to the following instructions in order to ensure the image effect and long-term stable operation of the device.

Maintenance for lens and mirror surface

The lens and mirror surface are covered with antireflection coating, so it may produce hazardous substance and lead to performance reduction or scratch, dimness etc when it is stained with dust, grease, fingerprint and so on, please refer to the following methods to deal with once dirt is found:

Stained with dirt

Use oil-free soft brush or hair dries to remove it gently.

Stained with grease or fingerprint

Use soft cloth to wipe the water drop or oil gently to make it dry, then use oil-free cotton cloth or paper soaked with alcohol or detergent to wipe from the lens center to outward. It is ok to change the cloth and wipe several times if it is not clean enough.

Camera Body Maintenance

Use a soft dry cloth to clean the camera body when it is dirty, in case the dirt is hard to remove, use a clean dry cloth soaked with mild detergent and wipe gently, make it dry later. Don't use volatile solvent like alcohol, benzene, thinner and etc or strong detergent with abrasiveness, otherwise it will damage the surface coating or reduce the working performance of the device.

Maintenance for Dome Cover

Dome cover is an optical device, please don't touch or wipe cover surface directly during installation and use, please refer to the following methods to deal with once dirt is found:

Stained with dirt

Use oil-free soft brush or hair dries to remove it gently.

Stained with grease or fingerprint

Use soft cloth to wipe the water drop or oil gently to make it dry, then use oil-free cotton cloth or paper soaked with alcohol or detergent to wipe from the lens center to outward. It is ok to change the cloth and wipe several times if it is not clean enough.

Note

- **This manual is for reference only. Slight difference may be found in the user interface.**
- **All the designs and software here are subject to change without prior written notice.**
- **All trademarks and registered trademarks mentioned are the properties of their respective owners.**
- **If there is any uncertainty or controversy, please refer to the final explanation of us.**
- **Please visit our website or contact your local service engineer for more information.**